

Science
Design of Sample Question Paper
Class X
SA-I (2010-2011)

Total Marks : 80
MCQ : 16
Theory : 64

I) Weightage of questions

S.No.	Form of Question	Marks for each question	No. of questions	Total Marks
1.	VSA	1	4	4
2.	SA (I)	2	9	18
3.	SA (II)	3	9	27
4.	LA	5	3	15
			25	64
	MCQ	1	16	16
	GRAND TOTAL			80

Distribution Chapterwise

S.No.	Content	Marks (Theory)	MCQ	Total
1	Chemical substances (i) Chem. Reactions & Equations (ii) Acids, Bases & Salts (iii) Metals and Non-metals	8 } 8 } 24 8 }	5	29
2.	Effects of current (i) Electricity (ii) Magnetic effects of current	11 } 10 }	5	26
3.	World of living (i) Life processes (ii) Control and coordination	7 } 6 }	6	19
4.	Natural resources Sources of energy	6 -	-	6

Form of Questions Unit	VSA	SA(I)	SA(II)	LA	Total
1. Chemical Substances					
(i) Chem. Reactions & Equations	1(1)	4(2)	3(1)	-	8(4)
(ii) Acids, Bases & Salts	-	2(1)	6(2)	-	8(3)
(iii) Metals and Non-metals	1(1)	2(1)	-	5(1)	8(3)
2. Effects of current					
(i) Electricity	1(1)	4(2)	6(2)	-	11(5)
(ii) Magnetic Effects of Current	-	2(1)	3(1)	5(1)	10(3)
3. World of living					
(i) Life processes	-	2(1)	-	5(1)	7(2)
(ii) Control and coordination	-	-	6(2)	-	6(2)
4. Natural Resources					
Sources of Energy	1(1)	2(1)	3(1)	-	6(3)
Total	4(4)	18(9)	27(9)	15(3)	64(25)

Sample Question Paper
Science (Theory)
First Term (SA-I)
Class X
2010-2011

Time: 3 to 3½ hours

M.M.: 80

General Instructions

- (i) The question paper comprises of two sections, A and B, you are to attempt both the sections.
- (ii) All questions are compulsory.
- (iii) There is no overall choice. However internal choice has been provided in all the three questions of five marks category. Only one option in each question is to be attempted.
- (iv) All questions of section A and all questions of Section B are to be attempted separately.
- (v) Question numbers 1 to 4 in Section A are one mark question. These are to be answered in one word or one sentence.
- (vi) Question numbers 5 to 13 are two marks questions, to be answered in about 30 words.
- (vii) Question numbers 14 to 22 are three marks questions, to be answered in about 50 words.
- (viii) Question numbers 23 to 25 are five mark questions, to be answered in about 70 words.
- (ix) Question numbers 26 to 41 in section B are multiple choice questions based on practical skills. Each question is a one mark question. You are to choose one most appropriate response out of the four provided to you.

Section-A

1. Write a balanced chemical equation to represent the following reaction :
Iron reacts with steam to form Iron (II, III) oxide and hydrogen gas.
2. Surface of some metals lose their brightness when kept in air for a long time. Why?
3. Mention one feature of biogas that makes it an ideal fuel.
4. State and define the unit of current.
5. The atomic number of sodium is 11, fluorine is 9 and neon is 10. Why are sodium and fluorine very reactive while neon shows almost no reactivity.
6. A drop of litmus solution is added to each of the four solutions given below. State the colour of litmus solution observed in each : soap solution, sodium carbonate solution, vinegar, lemon juice
7. Identify the substance oxidized, substance reduced, oxidizing agent and reducing agent :
$$\text{MnO}_2 + 4 \text{HCl} \rightarrow \text{MnCl}_2 + 2\text{H}_2\text{O} + \text{Cl}_2$$
8. When water is added to a white powder 'A', vigorous reaction takes place and a large amount of heat is released. 'A' is also used for white washing. Identify 'A', write a chemical equation for its reaction with water and name the product.

9. Although bile juice has no digestive enzyme, it is still considered to be very important during digestion of food. Give two reasons.
10. The water in deeper sections of sea / ocean is much colder than that at the surface. Discuss how can this difference in temperature be exploited to obtain energy.
11. A piece of wire having resistance R is cut into four equal parts.
- How does the resistance of each part compare with the original resistance?
 - If the four parts are placed in parallel, how will the resistance of combination compare with the resistance of original wire?
12. (a) Magnetic field lines of two magnets are shown as follows. Name the poles of magnets facing each other.

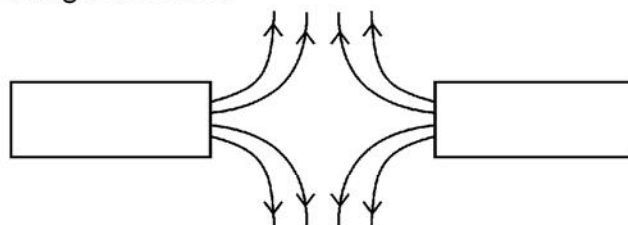

- (b) Why don't two magnetic field lines intersect with each other?
13. An electric room heater is rated at 2kW . Calculate the cost of using it for 2 hours daily for the month of September, if each unit costs Rs. 4.00.
14. 2g of ferrous sulphate crystals were heated in a hard glass test tube and observations recorded.
- What was the successive colour change?
 - Identify the liquid droplets collected on the cooler parts of the test tube.
 - What type of odour is observed on heating ferrous sulphate crystals?
 - Name the products obtained on heating ferrous-sulphate crystals.
 - What type of reaction is taking place.
15. Name the constituents of baking powder. What is the function of each constituent of baking powder in the manufacture of cake.
16. An apparatus was set up as shown in the figure. It was observed that when an aqueous solution of HCl was taken in the beaker and the circuit was closed, the bulb in the circuit began to glow, but it did not glow when the experiment was repeated with glucose solution. What could be the reason?

Would the bulb glow if the same experiment is repeated with an aqueous solution of (i) NaOH (ii) NaCl ? Why?

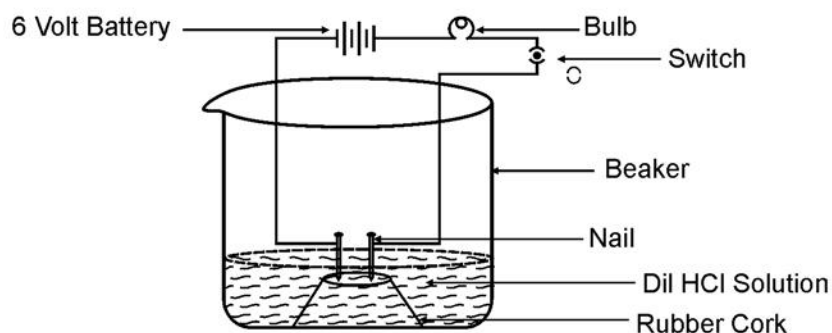

17. Name the plant growth hormone which is synthesized at the shoot tip. Explain briefly why does a plant shoot bend towards light during its growth.
18. With the help of a schematic diagram, trace the sequence of events occurring, when you step on a sharp object. Name this action.
19. State three advantages associated with using solar cells to produce electricity.
20. An electric circuit consisting of a 1.0m long metallic wire XY, an ammeter, a voltmeter, 4 cells of 1.5 V each and a plug key was set up.

Draw a schematic diagram of this electric circuit in the 'on' position.

Following graph was plotted between the values of potential difference (V) and current (I).

What conclusion do you draw about the relation between V and I from this graph. State this relation in your words.

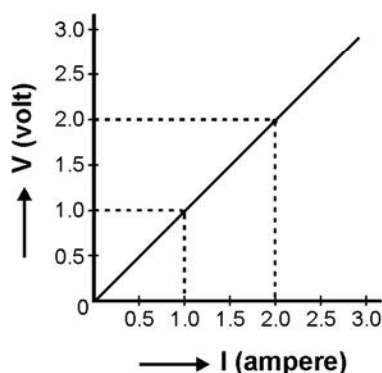

21. (a) Distinguish between the terms, electrical resistance and resistivity of a conductor.
 (b) A copper wire of resistivity 1.6×10^{-8} ohm meter has a cross sectional area of 20×10^{-4} cm². Calculate the length of this wire required to make a 10 ohm coil.
22. (a) State the function of 'a fuse' in a circuit. How is it connected in the domestic circuit?
 (b) An electric fuse of rating 3A is connected in a circuit in which an electric iron of power 1 kW is connected which operates at 220V. What would happen? Explain.
23. Account for the following :
- Melting and boiling points of ionic compounds are high.
 - Aluminium is more active than iron, yet there is less erosion of aluminium when both are exposed to air.
 - Solder is used for welding electrical wires together.
 - A sulphide ore is converted into its oxide to extract the metal.
 - Tarnished copper vessels are cleaned with tamarind juice.

OR

- (a) Giving one example of each, explain how the following metals are obtained from their compounds by the process of reduction.
- Metal 'A' which is low in the activity series of metals.
 - Metal 'B' which is in the middle of the activity series of metals.

- (iii) Metal 'C' which is high in the activity series of metals.
- (b) What is meant by refining of metals? In the electrolytic refining of metal M, name the cathode, anode and the electrolyte.
24. (a) Draw a neat diagram of an excretory unit of a human kidney and label the following parts.
- (i) Bowman's capsule
 - (ii) Renal artery
 - (iii) Glomerulus
 - (iv) Collecting duct
- (b) Give one advantage of having a large number of these highly coiled structures in our kidneys.
- (c) Mention any two substances which are selectively reabsorbed as the filtrate flows along the tubular part of this unit.

OR

- (a) Draw a neat diagram of the human respiratory system and label the parts.
- (i) that has cartilagenous rings
 - (ii) that encloses the vocal cords.
 - (iii) sheet of muscle that separates the chest cavity from the abdominal cavity.
 - (iv) serves as a common passage for food and air.
- (b) How are the alveoli designed to maximize the exchange of gases. Suggest any two features.
25. Draw the pattern of magnetic field lines through and around a current carrying solenoid. What does the magnetic field pattern inside the solenoid indicate?
How can this principle be utilized to make an electromagnet?
State two ways by which strength of this electromagnet can be increased?

OR

- (i) Describe an activity to show how a moving magnet may be used to generate an electric current. State the rule to find the direction of electric current generated in the coil.
- (ii) A coil 'A' of insulated copper wire is connected to a galvanometer. What would you observe when :
 - a. a current carrying coil 'B' is brought near 'A'?
 - b. strength of current in coil B is changed?

Section 'B'

26. On putting a few drops of a liquid on a pH strip, the colour of pH strip changed to green. The liquid is most probably
- a. Lemon juice

- b. dil HCl
 - c. NaOH solution
 - d. Water
27. When a few drops of universal indicator were added to a dilute solution of HCl, it is observed that the colour of the solution changes from
- a. Colourless to blue
 - b. Colourless to red
 - c. Blue to colourless
 - d. Colourless to green
28. Rahul took some zinc granules in a test tube and added dilute HCl to it. He observed that the colour of the zinc granules changed to
- a. Yellow
 - b. Brown
 - c. Black
 - d. White
29. Aluminium powder was added to a solution of copper sulphate. The colour of the solution changed from :
- a. Colourless to blue
 - b. Blue to colourless
 - c. Light green to blue
 - d. Reddish brown to light green
30. When a solution of barium chloride in water is added to an aqueous solution of sodium sulphate, the following happens:
- a. a white precipitate is formed
 - b. a red precipitate is formed
 - c. the colour of the solution turns blue
 - d. a pungent smelling gas is evolved
31. While performing the experiment to study the dependence of current on potential difference, if the circuit that is used to measure current and voltage is kept 'on' for a long time, then
- a. the voltmeter will start giving wrong readings
 - b. the ammeter's zero error will change
 - c. the resistor will get heated up changing the value of 'R'
 - d. the potential difference of the cell will change

32. The normal positions of two ammeters and two voltmeters are shown. For verification of ohm's law, the student should select:

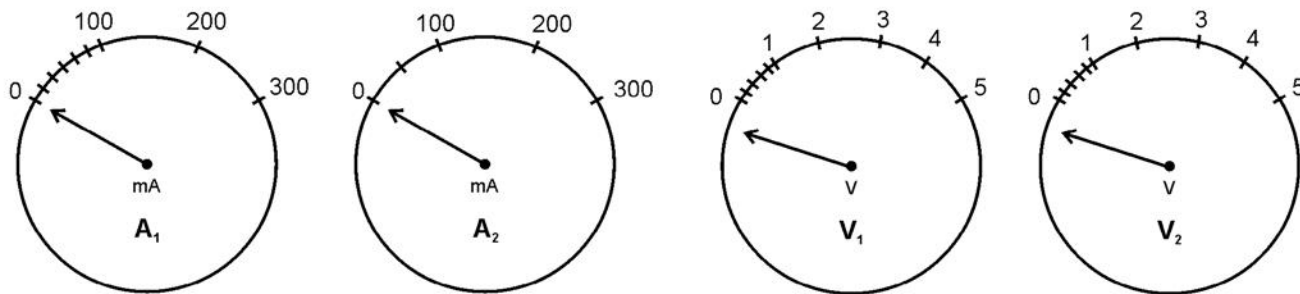

- a. ammeter A₁ and voltmeter V₁
- b. ammeter A₂ and voltmeter V₁
- c. ammeter A₁ and voltmeter V₂
- d. ammeter A₂ and voltmeter V₂

33. While performing the experiment to study the dependence of current on potential difference, across a resistor, following observations were made by four students, A, B, C and D.

Student	Reading 1	Reading 2	Reading 3
A	V=0.5A I=0.1A	V=1.0V I=0.2A	V=1.5V I=0.3A
B	V=0.8V I=0.4A	V=1.6V I=0.8A	V=2.4V I=1.2A
C	V=1.0V I=0.5A	V=1.2V I=1.4A	V=1.4V I=1.0A
D	V=2.4A I=0.8A	V=2.7V I=0.9A	V=3.0V I=1.0A

The student who made wrong observation is :

- a. A
- b. B
- c. C
- d. D

34. To determine the equivalent resistance of three resistors, when connected in a parallel arrangement, four students connected the resistors as follows :

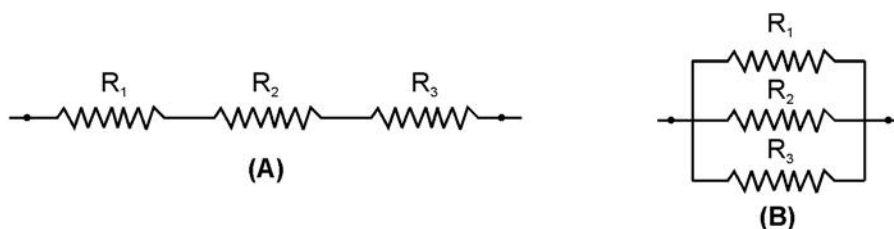

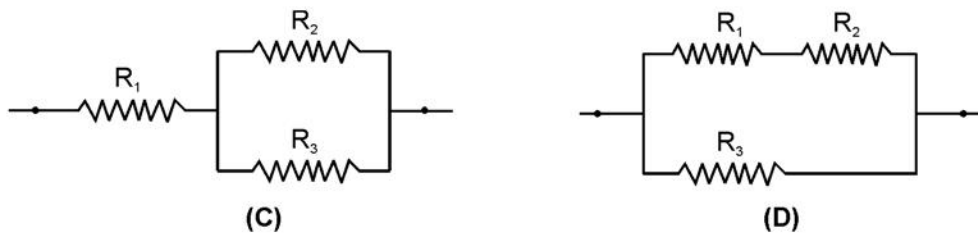

The correct set up is that of student :

- a. A
- b. B
- c. C
- d. D

35. To determine the equivalent resistance of two resistors, when connected in series, the correct way of connecting the ammeter and voltmeter in the circuit is :

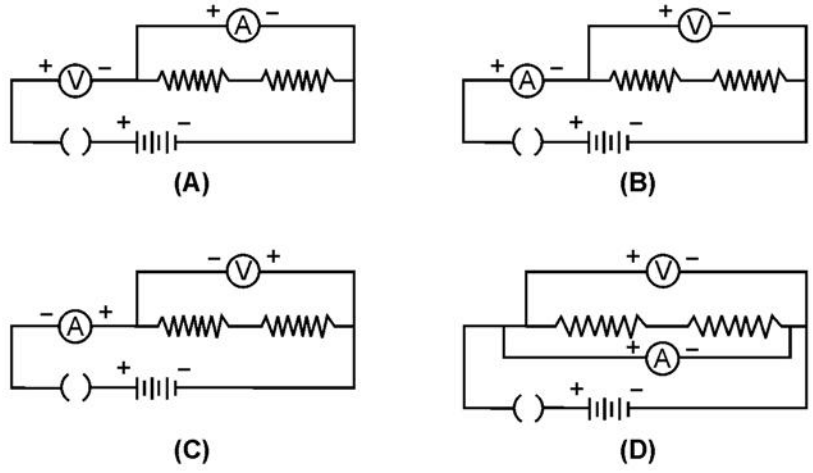

36. We test for starch and not glucose to prove that photosynthesis has taken place because:

- a. Glucose is not produced during photosynthesis in variegated leaves.
- b. Glucose formed during photosynthesis gets stored as sucrose.
- c. Glucose formed during photosynthesis gets stored as starch.
- d. Glucose is a stable product and cannot be tested.

37. The figure that correctly depicts the removal of chlorophyll is

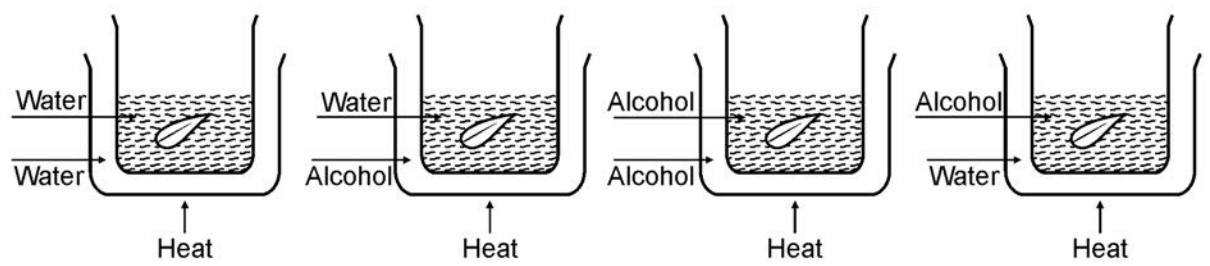

- a. I
- b. II
- c. III
- d. IV

38. Given below is the figure of a stomata. Select the correct labelling for this diagram.

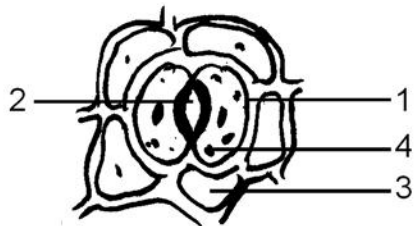

- a. 1. Epidermal cells 2. Stoma 3. Guard cell 4. Chloroplast
- b. 1. Guard cell 2. Stoma 3. Epidermal cells 4. Chloroplast
- c. 1. Stoma 2. Epidermal Cells 3. Chloroplast 4. Guard Cell
- d. 1. Chloroplast 2. Stoma 3. Epidermal Cell 4 Guard Cell

39. Stomata plays an important role in

- a. Respiration
- b. Photosynthesis
- c. Transpiration
- d. All the above

40. Given below to the diagram of the experiment set up to show carbon dioxide is given out during respiration. The part which is incorrectly labelled is

- a. KOH pellets
- b. Delivery tube
- c. Germinating seeds
- d. Lime water

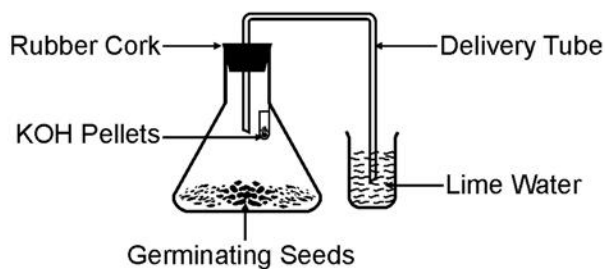

41. In the experiment shown in the figure given below, the water level rises in the bent tube because.

- a) The germinating seeds consume all the oxygen and carbon dioxide.
- b) The germinating seeds consume oxygen and give out carbon dioxide which is absorbed by KOH.
- c) Carbondioxide is given out by the germinating seeds.
- d) Seeds need water for germination.

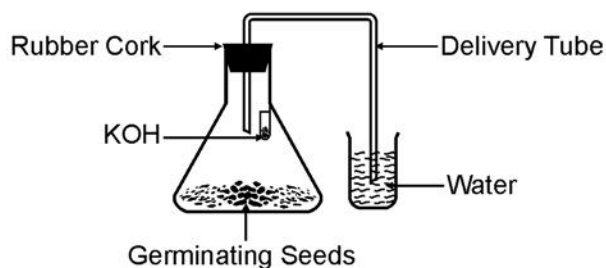

**Marking Scheme
Science (Theory)
First Term (SA-I)
Class X
2010-2011**

Section A

- | | | |
|-----|---|------------------------|
| 1. | $3\text{Fe} + 4\text{H}_2\text{O} \rightarrow \text{Fe}_3\text{O}_4 + 4\text{H}_2$ | 1 |
| 2. | They react with constituents of air (oxygen, carbon dioxide, moisture etc.) to form compounds. | 1 |
| 3. | Burns without smoke / leaves no residue / has high calorific value (any one). | 1 |
| 4. | Ampere | $\frac{1}{2}$ |
| | 1 ampere is the amount of current flowing when a charge of 1 coulomb flows through a conductor in 1 second. | $\frac{1}{2}$ |
| 5. | Sodium has one electron more (2,8,1) and fluorine has one electron less (2,7) than stable configuration. | 1 |
| | Neon has a stable configuration (2,8,8). | 1 |
| 6. | Soap solution : Blue | |
| | Sodium carbonate solution : Blue | |
| | Vinegar : red | |
| | Lemon juice : Red | |
| | Substance oxidized : HCl | |
| | Substance reduced : MnO_2 | |
| | Oxidizing agent : MnO_2 | |
| | Reducing agent : HCl | $\frac{1}{2} \times 8$ |
| 8. | Calcium oxide / Quick lime / CaO | $\frac{1}{2}$ |
| | $\text{CaO} + \text{H}_2\text{O} \rightarrow \text{Ca}(\text{OH})_2 + \text{heat}$ | 1 |
| | Product : Calcium hydroxide / slaked lime | $\frac{1}{2}$ |
| 9. | Makes the medium alkaline for the action of pancreatic enzyme. | 1 |
| | Emulsification of fats. | 1 |
| 10. | By use of ocean thermal energy conversion plants; warm surface water is used to boil volatile liquid; vapours are used to turn the turbine of the generator; colder water from the depth is pumped up, it helps in condensing the vapour into liquid. | $\frac{1}{2} \times 4$ |
| 11. | a. Resistance of each part becomes 1/4th the original vaue. | 1 |
| | b. $R_p = \frac{R}{n} = \frac{R/4}{4} = \frac{R}{16}$ | 1 |

It becomes 1/16th the original vaue.

12. i. North poles 1
 ii. Intersection of field lines implies that the compass needle would point towards two directions at that point, which is not possible. 1
13. E = P x t x no. of days 1/2
 = 2kw x 2h x 30 1/2
 = 120 kwh
 E = 120 units 1/2
 ∴ Cost= Rs. 4.00 x 120 1/2
 = Rs. 480.00
14. i. Green to white, then brown 1/2, 1/2
 ii. Water 1/2
 iii. As of burning sulphur 1/2
 iv. Ferric oxide, sulphur dioxide, sulphur trioxide 1/2
 v. Décomposition réaction 1/2
15. Baking soda / NaHCO₃ 1/2
 Tartaric acid (a mild edible acid) 1/2
 Baking soda releases CO₂ on heating and causes the cake to rise/ make it soft and spongy. 1
 Tartaric acid neutralizes the effect of (bitter taste) of the sodium salt of the acid formed. 1
16. The bulb could glow when an aqueous solution of HCl was taken because HCl (aq) provided hydrogen and chloride (H⁺ and Cl⁻) ions which are carriers of electric charges in a solution, while glucose (being a covalent compound) did not furnish any ions in the solution. 1
 i. NaOH : The bulb will glow 1
 ii. NaCl : The bulb will glow 1
 Because both of them being ionic compounds furnish ions in aqueous solutions.
17. Auxins, when the growing shoot of a plant detects light, auxin is synthesised at the shoot tip and diffuses towards the shady side of the shoot. This stimulates cells to grow longer on the shadier side causing the plant to bend. 1/2 + 2 1/2
18. Stimulus received by the receptor cells → Sensory neuron → Spinal cord (relay neuron) ↓ Motor neuron → Effector (muscle) 5x1/2=2 1/2
 Reflex action. 1/2
19. Can be set up in remote areas where power transmission line is not commercially viable, have no moving parts / need no maintenance, need no focusing device, pollution free. (any 3) 3

20. i.

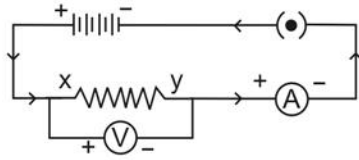

- placement of ammeter and volt meter 1/2
- direction of current 1/2
- placement of 4 cells in series 1/2
- closed key 1/2

ii. $V \propto I$

Current flowing through a conductor is directly proportional to the potential difference across it, if other physical conditions are constant. 1

21. i.

Electrical resistivity of a conductor remains constant at a particular temperature, whereas, electrical resistance of a conductor changes with change in length or area of cross section of the conductor. 1

ii. $R=10\Omega$ $\rho=1.6 \times 10^{-8} \Omega m$ $A=20 \times 10^{-4} cm^2$
 $=20 \times 10^{-8} m^2$

$$R = \frac{\rho \ell}{A} \quad \text{span style="float: right;">1/2$$

$$\begin{aligned} \therefore \ell &= \frac{RA}{\rho} \\ &= \frac{10\Omega \times 20 \times 10^{-8} m^2}{1.6 \times 10^{-8} \Omega m} \quad \text{span style="float: right;">1/2} \\ &= \frac{2000}{16} m \end{aligned}$$

$\ell = 125m$ (answer with correct unit) 1

22. i.

- It prevents damage to the appliance and the circuit due to overloading. 1/2
- It is connected in series with the household circuit. 1/2

ii. $I = \frac{P}{V}$

$$\begin{aligned} &= \frac{1kw}{220v} = \frac{1000W}{220v} \\ &= 4.55A \end{aligned}$$

The electric current flowing / required by the electric iron is more than the current that can flow through the fuse without its melting.

Hence, fuse wire will melt, circuit breaks and the electric iron will not work. 2

23. a. Large amount of heat energy is required to break the inter-ionic attractive forces.
 b. A thin but strong layer of aluminium oxide is formed on its surface which protects aluminium atoms underneath.
 c. Solder has a low melting point.
 d. It is easier to extract a metal from its oxide by the process of reduction than from its sulphide.
 e. Tamarind juice is acidic and neutralizes the basic layer of copper carbonate on tarnished copper vessels. 1x5

OR

- a. i. By heating
 Exmple : $\text{HgS} + \text{O}_2 \xrightarrow{\text{heat}} \text{Hg} + \text{SO}_2$ 1
- ii. By reduction of its oxide with carbon / carbon monoxide
 Example: $\text{ZnO} + \text{C} \longrightarrow \text{Zn} + \text{CO}$ 1
- iii. By electrolysis of fused compounds of the metal
 Exmple : $2\text{NaCl} \xrightarrow{\text{electricity}} 2\text{Na} + \text{Cl}_2$
 (molten) 1
- b. Removal of impurities from the crude metal. ½
 Cathode : Pure M ½
 Anode : Impure (crude) M ½
 Electrolyte : A water soluble salt of M. ½
24. a. Fig. 6.14 page 111, NCERT text book, labelling 1, ½ x 4
 b. Help in increasing the surface area for filtration/ help in increasing the surface area for proper reabsorption of useful substance. 1
 c. Glucose, amino acids, salts, water (any two) ½ x 2
- OR
- a. Fig. 6.9 page 104, NCERT text book 1
 Label :
 i. Trachea
 ii. Larynx
 iii. Diaphragm
 iv. Pharynx ½ x 4
- b. Thin walled (easy diffusion), greater surface area for diffusion, large number, highly elastic, surrounded by network of blood capillaries. ½ x 4

25.

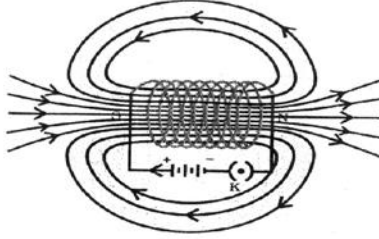

Pattern	1
Correct Direction	1
Magnetic field pattern inside the solenoid indicates that the magnetic field is same at all points inside the solenoid.	1
This principle is utilized to magnetise a piece of magnetic material like soft iron when placed inside the coil.	1
Ways to strengthen this electromagnet :	
i. Increase the amount of electric current through it	$\frac{1}{2}$
ii. Increase the number of turns of coil.	$\frac{1}{2}$

OR

- (i) Activity :
- Take a coil of wire, AB, having a large number of turns and connect it to a galvanometer.
 - Move the north pole of a strong bar magnet towards one end, B, of the coil. The galvanometer shows a momentary deflection indicating the presence of electric current in the coil AB.
 - When the magnet is withdrawn / taken away from the coil, the galvanometer again shows momentary deflection in a direction, opposite to the first, indicating that the current is set up in the opposite direction. 2

Rule :

Fleming's right hand rule : stretch the thumb, forefinger and middle finger of right hand so that these are perpendicular to each other. If the forefinger indicates the direction of the magnetic field and the thumb shows the direction of motion of the conductor, then the middle finger will show the direction of current generated in the coil. 1

- ii. a) The galvanometer shows a momentary deflection (due to electric current induced in it) 1
- b) The galvanometer shows a momentary deflection (due to change in amount of electric current). 1

Section 'B'

- 26. d
- 27. b
- 28. c
- 29. b
- 30. a
- 31. c
- 32. a
- 33. c
- 34. b
- 35. b
- 36. c
- 37. d
- 38. b
- 39. d
- 40. d
- 41. b